

Development of Super-Precise Evaluation Method for EUVL-Grade Ultra-Low-Expansion Glass Using the Line-Focus-Beam Ultrasonic Material Characterization System

Jun-ichi Kushibiki

Department of Electrical Engineering, Tohoku University
Sendai, 980-8579 Japan
kushi@ecei.tohoku.ac.jp

Abstract—It is crucial to develop and produce extremely homogeneous ultra-expansion glass with zero coefficient of thermal expansion (CTE) characteristics for next-generation extreme ultraviolet lithography (EUVL) technology. We have proposed and developed a new method of precisely measuring the phase velocity of leaky surface acoustic waves excited and propagated on a water-loaded specimen surface using the line-focus-beam ultrasonic material characterization (LFB-UMC) system. This technique allows nondestructive and noncontact two-dimensional analysis and evaluation of the CTE characteristics of EUVL-grade glass substrate surface that are important for reflective optics employed in EUVL systems, with much higher accuracy than conventional techniques. Our ultrasonic method is expected to become a standard evaluation method not only for developing EUVL-grade glass and improving production conditions, but also for quality control and the selection of production lots. In this review, we summarize the demonstrational results for the practical use of commercial ultralow-expansion TiO_2 -doped SiO_2 glass.

Keywords: *line-focus-beam ultrasonic material characterization system, velocity measurement, leaky surface acoustic wave, ultra-low-expansion glass, TiO_2 - SiO_2 glass, coefficient of thermal expansion evaluation, extreme ultraviolet lithography*

I. INTRODUCTION

System development of extreme ultraviolet lithography (EUVL) has been intensively conducted in the semiconductor nanoelectronics field to provide a future key technology to mass-produce Super-LSI circuits with a line width of less than 32 nm. The most important issue to realize the EUVL system is to develop ultra-low-expansion glasses as the basic substrate material suitable for reflective optics and photomask blanks, having a coefficient of thermal expansion (CTE) within ± 5 ppb/K at a desired operating temperature (for example, $22 \pm 3^\circ\text{C}$ for EUVL mask blanks) [1]. Two types of TiO_2 -doped SiO_2 (TiO_2 - SiO_2) glass [2, 3] and crystalline glass ceramic of Li_2O - Al_2O_3 - SiO_2 compositional system [4, 5] are the candidate materials, and there is a worldwide production competition.

To develop extremely homogeneous ultra-low expansion glasses with satisfactory CTE characteristics, it is important to evaluate the fabricated glasses so that the obtained information can be used to improve the glass fabrication processes. Methods to evaluate CTE include a direct method [6, 7], in which CTE is measured by a dilatometer with an interferometric system, and indirect methods [1, 8-10], in which CTE is determined by measuring ultrasonic longitudinal velocities, chemical compositions, or refractive indices, which are closely related to the thermal properties of CTE. With the direct method, the Association of Super-Advanced Electronics Technologies (ASET) has recently succeeded in achieving a resolution of ± 2 ppb/K ($\pm 2\sigma$, σ : standard deviation) [7]. Among the indirect measurement methods, a method using refractive indices has a higher resolution of ± 0.038 ppb/K ($\pm 2\sigma$) [1, 8]. However, both of these methods are only capable of measuring the average characteristics of specimens of 100 mm in thickness, and therefore they cannot be applied to characterization of the substrate surfaces, which is essential for evaluating ultra-low expansion glasses for EUVL. No conventional technologies meet the requirement.

To resolve the problem, we have proposed and demonstrated an evaluation method for ultra-low expansion glasses using the line-focus-beam ultrasonic material characterization (LFB-UMC) system [11-19]. This ultrasonic method enables evaluating the CTE characteristics through highly accurate measurement of the phase velocity of leaky surface acoustic waves (LSAWs) excited and propagated on a water-loaded specimen surface. The remarkable advantages are presented in Fig. 1, in comparison with the specifications of the CTE measurement system developed most recently. The ultrasonic system has all the capabilities required for characterization and evaluation of EUVL-grade ultra-low-expansion glasses. This system is capable of nondestructive and noncontact analysis of two-dimensional CTE distributions on substrate surfaces with a very high resolution of better than ± 0.3 ppb/K, without changing the specimen temperature and for a relatively short measurement time. Glass manufacturers can apply this system not only for developing EUVL-grade glasses and evaluating the

Superior Advantages of LSAW Velocity Measurements	
(1) Super high accuracy: $\pm 0.002\%$	\Rightarrow CTE = ± 0.3 ppb/K
(2) Nondestructive and noncontact evaluation	
(3) Surface properties	\Rightarrow EUVL(Reflective optics)
(4) Research & development	\Rightarrow Improving process
(5) Quality control	\Rightarrow Selection (Zero-CTE substrate)
(6) Measurement time	\Rightarrow Relatively short

Problems on Recent System for CTE Measurement	
(1) High accuracy	\Rightarrow ± 2 ppb/K
(2) Destructive evaluation	\Rightarrow 30 mm \times 10 mm \times 100 mm ^t
(3) Bulk property (average along thickness direction)	
(4) No possibility to evaluate 2-D properties	
(5) Measurement time	\Rightarrow Very long

Fig. 1. Comparison of specifications by LSAW velocity measurement and the latest direct CTE measurement.

production processes, but also for quality control and selection of the production lots, and glass users can inspect and select all the substrates for proper use.

In this review, we present the promising method of evaluating and selecting the EUVL-grade TiO₂-SiO₂ glasses using the LFB-UMC system, with the demonstrational results concerning periodic striae analysis and relationships among LSAW velocity, TiO₂ concentration, and CTE.

II. SPECIMENS

Commercial TiO₂-SiO₂ ultra-low expansion glasses with different premium- and mirror-grade (C-7972, Corning Inc.) were used to prepare several specimens. Corning Inc. is making quality-control of the glasses through the longitudinal-wave velocity measurements [1, 9]. The specifications for CTE are provided in the catalog that the absolute value is 0 ± 30 ppb/K at 5-35°C and the homogeneities are within 10 ppb/K for the premium-grade ingot and 15 ppb/K for the mirror-grade ingot. The glass C-7972 was produced by deposition in a rotating refractory container with many burners by the direct method, using a flame hydrolysis process, and in the form of a large circular plate glass ingot of 1500 mm in diameter and 150 mm in thickness. It was reported that periodic striae with an interval of about 0.16 mm are formed perpendicularly to the glass deposition direction due to the condition of the production process [10].

We prepared two types of specimen substrates cut from the ingot with the striae plane perpendicular to the z axis as illustrated in Fig. 2(a): the substrate surfaces were parallel

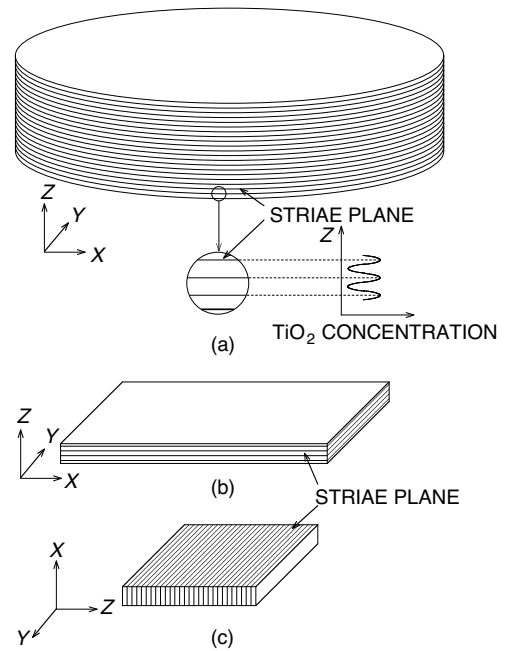

Fig. 2. Specimen preparation. (a) Glass ingot. (b) Specimen with the substrate surface prepared parallel to the striae plane (parallel specimen). (c) Specimen with the substrate surface prepared perpendicular to the striae plane (perpendicular specimen).

(Fig. 2(b)) and perpendicular (Fig. 2(c)) to the striae plane. We prepared a total of seven perpendicular specimens from four different ingots to obtain a standard specimen for system calibration and to determine an accurate relationship between LSAW velocities and TiO₂ concentrations.

In order to discuss evaluation procedures of TiO₂-SiO₂ glasses of 6-inch photomasks for EUVL systems, two parallel specimens, as illustrated in Fig. 2(b), were prepared for premium-grade specimen (specimen A) and for mirror-grade specimen (specimen B).

All the specimens were prepared with both sides optically polished.

III. LFB-UMC SYSTEM AND MEASUREMENT REGION

LSAW velocities were measured with the LFB-UMC system [20] at an ultrasonic frequency f of 225 MHz. The measurement principle of the LSAW velocity is described in detail in the literature [21]. Fig. 3(a) is a cross section of the LFB lens and a specimen with periodic striae, illustrating the measurement principle of the $V(z)$ curve. Fig. 3(b) shows the measurement region $W \times D$ on the specimen surface. A typical $V(z)$ curve measured for C-7972 is given in Fig. 4(a). A spectrum distribution as shown in Fig. 4(b) is obtained from this waveform by the $V(z)$ curve analysis. The oscillation interval Δz obtained from the result of this analysis is

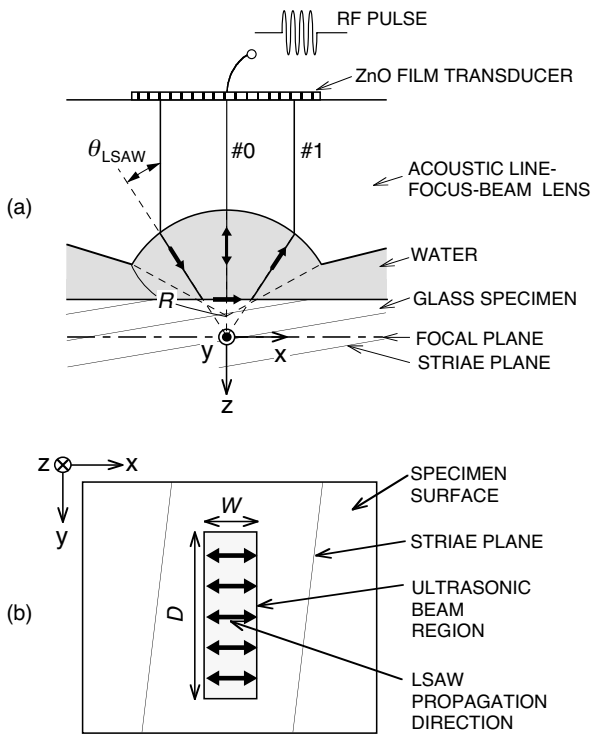

Fig. 3. Measurement principle. (a) Cross-sectional geometry of the LFB ultrasonic device describing the principle of $V(z)$ curve measurements. The focal length F in water is equal to $1.15R$, where R is the curvature radius of cylindrical sapphire acoustic lens. (b) Measurement region of the LFB at a specific defocus distance formed on the specimen.

substituted into Eq. (1) to obtain the LSAW velocity V_{LSAW} .

$$V_{LSAW} = \frac{V_w}{\sqrt{1 - \left(1 - \frac{V_w}{2f\Delta z}\right)^2}} \quad (1)$$

where V_w is the velocity of the longitudinal waves in water. The mechanical system, including an LFB ultrasonic device and a sample stage with a specimen, was installed in the temperature control chamber system, in which the measurement environment of the water couplant temperature was stabilized within $\pm 0.01^\circ\text{C}$ around 23°C [20]. Absolute calibration was performed using a C-7972 standard specimen [13] to obtain the absolute value of the LSAW velocity [22]. The measurement reproducibility of the LSAW velocity was estimated at 225 MHz to be within ± 0.17 m/s ($\pm 0.0053\%$, $\pm 2\sigma$).

When the ultrasonic measurement region was larger than the periodicity of the striae on the specimen surface, the measured values of the LSAW velocity were averaged within the region. The maximum value of the propagation distance of LSAWs in the focused direction W on the specimen surface was $280 \mu\text{m}$ in the measurement for C-7972 at 225

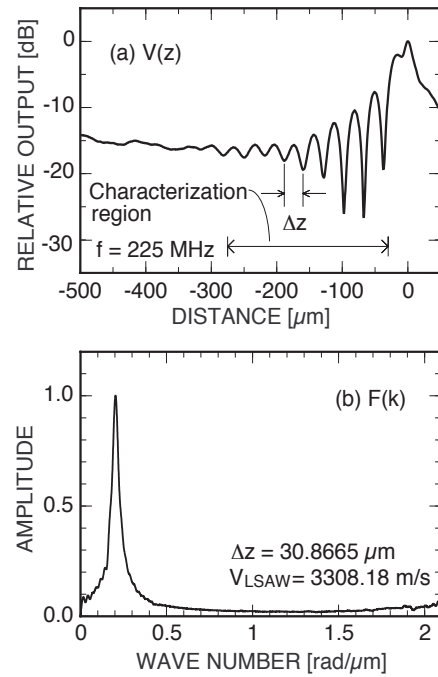

Fig. 4. Typical $V(z)$ curve measured for C-7972 specimen at 225 MHz (a) and spectral distribution analyzed by FFT for the $V(z)$ curve shown above (b).

MHz. The measurement region in the unfocused direction D depends on the operating parameters of the ultrasonic device, and the value used in this experiment was approximately $900 \mu\text{m}$. As 70 % of Rayleigh-type LSAWs' energy is confined within 0.4 wavelength below the surface as they propagate, the resolution in the depth direction is approximately $6 \mu\text{m}$ at 225 MHz. The effect of averaging LSAW velocities on specimens with periodic striae was investigated through the numerical calculations, and it was concluded that the true value could be obtained when the periodicity of the striae was larger than 1.6 mm [17] in the measurements at 225 MHz.

IV. EXPERIMENTS AND DISCUSSIONS

4.1 Calibration Line for Chemical Composition and Standard Specimen

The LSAW velocity measurements were carried out in 2-mm steps along both the y - and z -axis directions for an area of $24 \text{ mm} \times 24 \text{ mm}$ around the center of seven perpendicular specimens. The LSAWs propagated on the surface of the perpendicular specimens in the y -axis direction. Among the seven specimens, the maximum difference in the averaged LSAW velocities was 4.07 m/s and the maximum value in the maximum velocity variations was 1.87 m/s. We analyzed chemical compositions of the seven specimens using an X-ray fluorescence analysis (XRF) system. Measurements were made for an area of 25 mm^2 around the center of each specimen. The values measured by XRF analysis were

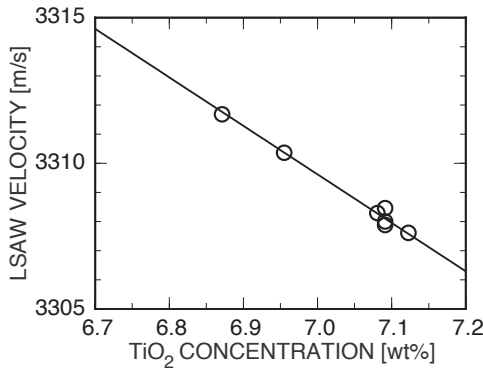

Fig. 5. Relationships between LSAW velocities and TiO₂ concentrations. Open circles: measured. Solid line: approximated by the least-squares method.

Table 1. Sensitivities and resolutions for CTE, TiO₂ concentration, and density for C-7972 glass by LSAW velocity measurements.

	Sensitivity /(m/s)	Resolution ($\pm 2\sigma$)	
		225 MHz	75 MHz
LSAW velocity (m/s)		± 0.17	± 0.07
CTE (ppb/K)	4.41	± 0.74	± 0.29
TiO ₂ conc. (wt%)	-0.0601	± 0.010	± 0.004
Density (kg/m ³)	0.0176	± 0.0029	± 0.0011

calibrated by values coupled plasma - optical emission spectrometry (ICP-OES) system. In order to obtain an accurate gradient, we added the LSAW velocity for the standard specimen of synthetic silica glass of C-7980 measured by an inductively (Corning Inc.) with 100-percent SiO₂ [23]. The result of a relationship between the LSAW velocities and calibrated TiO₂ concentrations $C(\text{TiO}_2)$ (wt%) can be obtained as shown in Fig. 5.

A specimen, having the least LSAW velocity distribution, among the seven perpendicular specimens was chosen as a standard specimen of C-7972. The LSAW velocity was 3308.18 ± 0.35 m/s and the corresponding TiO₂ concentration was 7.09 wt%. The densities were 2197.74 kg/m^3 for the C-7972 standard specimen and 2199.82 kg/m^3 for the C-7980 standard specimen [23]. The CTE for the C-7980 standard specimen is typically 520 ppb/K around 23°C, and that for the C-7972 standard specimen is assumed to be 0 ppb/K. The sensitivities and resolutions of LSAW velocity to the CTE, TiO₂ concentration, and density were presented in Table 1. We can determine the resolution of the LSAW velocity at 225 MHz to the TiO₂ concentration as ± 0.010 wt% for $\pm 2\sigma$ and that for CTE was ± 0.74 ppb/K.

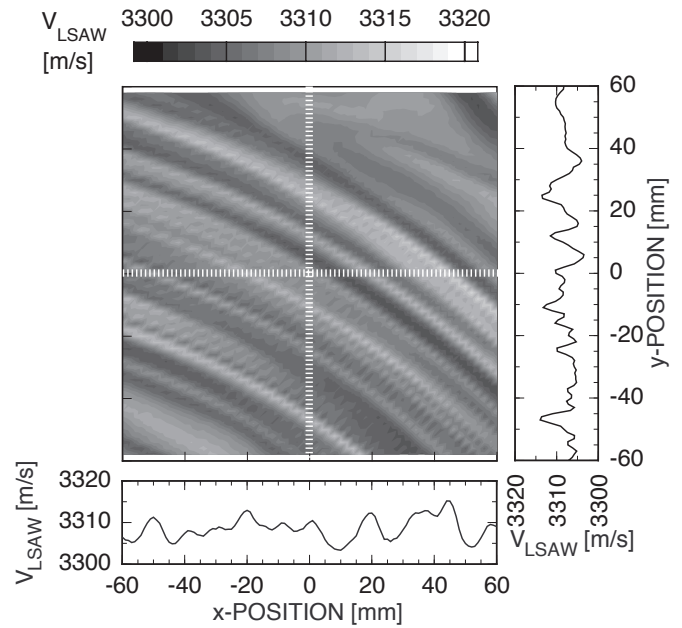

Fig. 6. LSAW velocity distributions for two-dimensional scanning for C-7972 specimen A. White dotted lines show the measurement positions of line-scanning.

4.2 Evaluation and Selection of EUVL-Grade TiO₂-SiO₂ Ultra-Low-Expansion Glasses

Two-dimensional LSAW velocity distributions were measured for specimens A and B together with the line-scanning measurements along x - and y -axes. The results for specimen A are presented in Fig. 6. Striae were observed with LSAW velocity distributions of two-dimensional periodicities. These results reflect the glass production-process conditions such as the arrangement of the multiple burners, the rotation speed of refractory container, the glass liquid flow, and the temperature distributions on the glass deposit surfaces and within the container. So, measured data of the striae parameters of periodicity and magnitude in the variations must be very useful for improving the production process conditions to obtain more homogeneous glass for EUVL systems. Table 2 shows the measured LSAW velocities and TiO₂ concentrations, and estimated variations in CTE for specimens A and B. Using the previously determined relationships among them, the averaged TiO₂ concentrations were obtained from the averaged LSAW velocities, and the maximum variations in the TiO₂ concentration and CTE were converted from the maximum variations in the LSAW velocity. There are no significant differences between the velocity measurement results by two-dimensional scans and two line scans. The maximum velocity variations were 12.98 m/s for specimen A and 7.68 m/s for specimen B, and they correspond to the CTE variations of 57.2 ppb/K and 33.8 ppb/K, respectively. The estimated CTE variations were 5.7 and 2.3 times larger than the specifications and the variations for the premium grade

Table 2. Comparison of LSAW velocities and corresponding TiO₂ concentrations and CTE in the 2-dimensional scanning and line scanning measurements.

Specimen		A		B	
Size (mm)		136 × 134 × 9.98		229 × 149 × 6.75	
Measurement method		2-D scan	Line scan	2-D scan	Line scan
LSAW velocity (m/s)	Average	3308.10	3308.23	3307.33	3307.22
	Variation	12.98	11.84	7.68	7.28
TiO ₂ concentration (wt%)	Estimated av.	7.09	7.08	7.14	7.14
	Estimated var.	0.78	0.71	0.46	0.44
CTE (ppb/K)	Estimated var.	57.2	52.2	33.9	32.1
	Catalog	10 (premium grade)		15 (mirror grade)	

were greater than those for mirror grade. This is considered to be due to the fact that the manufacturer evaluates the CTE of the glass ingots by measuring the velocities of longitudinal waves propagating in the thickness direction of the ingots and their distributions [1, 9]. Therefore, CTE variations caused by striae on the specimen surface or in the glass ingots could not be detected accurately.

Based on the measurement results, we discuss evaluation methods of the EUVL-grade TiO₂-SiO₂ glasses in the developmental stage and in the stage after more homogeneous glass ingots can be obtained, and for quality control and selection in the mass production. The flowchart for evaluation, quality control, and selection is shown in Fig. 7.

In the development of the glasses, it is important to evaluate the absolute CTE and the parameters of periodic striae such as the periodicities, variations, and distributions. It is very useful to understand the striae structures by the two-dimensional measurements, as shown in Fig. 6. However, the number of measurements was too many. On the other hand, the number for line-scanning measurements was much less, and it is possible to obtain almost the same averaged velocities and maximum velocity variations as those of the two-dimensional measurements. So, data obtained by the two line scans are sufficient enough to evaluate the glasses in the developmental stage. The CTE characteristics of TiO₂-SiO₂ ultra-low-expansion glasses are adjusted by controlling the concentration of TiO₂ [2]. Therefore, TiO₂ concentrations are calculated from the averaged LSAW velocities using the calibration line, and the obtained data should be fed back to the glass fabrication conditions. The CTE within ±5 ppb/K needed for EUVL-grade ultra-low-expansion glass substrates are satisfied when LSAW velocity variations are within ±1.13 m/s. The velocity variations observed in Fig. 6 were not acceptable for the EUVL-grade glass.

In the stage after the glass production processes are improved to reduce striae and more homogenous ingots are produced, it is not necessary to measure LSAW velocities with fine steps. For example, we can obtain averaged TiO₂ concentrations from the averaged LSAW velocities sampled by line-scanning measurements with steps from several millimeters to several tens millimeters.

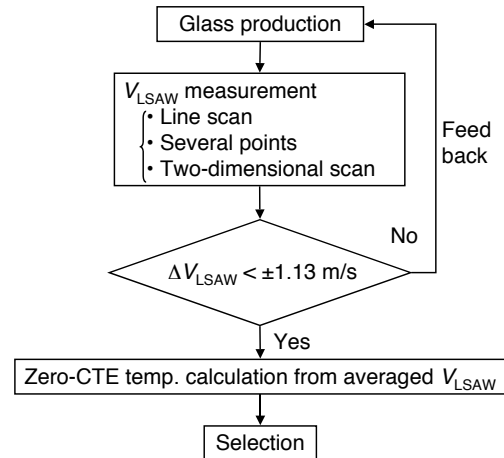

Fig. 7. Flowchart for evaluation, quality control, and selection of EUVL-grade TiO₂-SiO₂ glasses using the LFB-UMC system.

In the stage for mass production, it is necessary to conduct quality control and selection of the substrates suitable for different parts of the reflective optics in the EUVL system, having differently required CTE specifications, viz., temperatures at which CTE becomes zero (zero-CTE temperature). If the problems associated with striae are already resolved, it is possible to measure the LSAW velocities at several sampling points, such as 9 points, 5 points, ultimately only 1 point at center of the substrate and to select the substrates for desired use. Here, the results at 225 MHz were presented, but the higher CTE resolution of ±0.29 ppb/K (±2σ) was already demonstrated by choosing lower frequencies, such as 75 MHz, as given in Table 1 [15].

V. CONCLUSION

In this review, we discussed a method of evaluating and selecting EUVL-grade TiO₂-SiO₂ ultra-low-expansion glasses using the LFB-UMC system. This ultrasonic method can make nondestructive and noncontact analysis of CTE characteristics on specimen surfaces with much higher accuracy, and is very useful not only for evaluation to develop more homogeneous ultra-low expansion glasses in the developmental stage, but also for quality control and

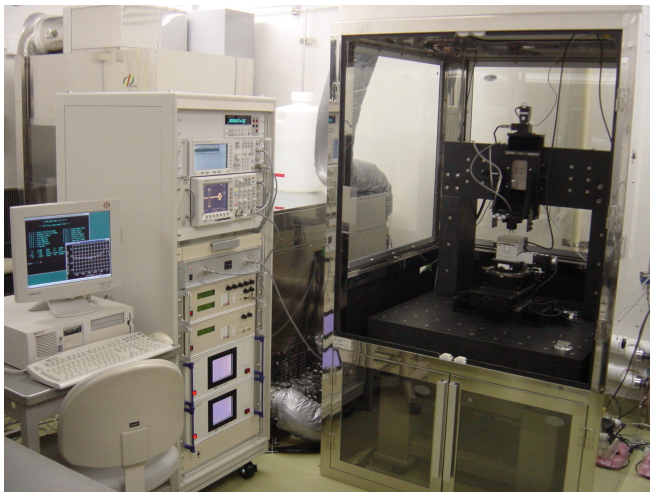

Fig. 8. Prototype system of LFB-UMC.

selection of the glass in the mass-production stage. When the EUVL-grade glass will be commercially available, only this method could be used for measuring zero CTE for all substrates in both manufacturers and users. This system can be applied to $\text{TiO}_2\text{-SiO}_2$ glasses produced by the vapor-phase axial deposition (VAD) method and the outside vapor-phase deposition (OVD) method, and this method will be able to be extended to evaluation of the crystalline glass ceramic of $\text{Li}_2\text{O-Al}_2\text{O}_3\text{-SiO}_2$ system. We are measuring the relationship between LSAW velocities and CTE. With this relation, we will be able to calculate the absolute CTE values and zero-CTE temperatures from measured LSAW velocities. We also developed a prototype system for practical use as shown in Fig. 8. Our ultrasonic method should be standardized for an evaluation method of the EUVL-grade ultra-low-expansion glasses.

ACKNOWLEDGEMENTS

The authors are very grateful to M. Arakawa, Y. Ohashi, K. Suzuki and S. Sannohe for their experimental assistance. This work was supported in part by a Research Grant-in-Aid for the 21st COE (Center of Excellence) Program funded by the Japanese Ministry of Education, Culture, Sports, Science, and Technology.

REFERENCES

[1] K. E. Hrdina, B. G. Ackerman, A. W. Fanning, C. E. Heckle, D. C. Jenne and W. D. Navan: Proc. SPIE **5037**, 227(2003).

[2] P. C. Schultz and H. T. Smyth: *Amorphous Materials*, eds. R. W. Douglas and B. Ellis, p.453 (Wiley-Interscience, New York, 1970).

[3] R. B. Gregor, F. W. Lytle, D. R. Sandstrom, J. Wong and P. Schultz: J. Non-Cryst. Solids **55**, 27(1983).

[4] R. Haug, W. Heimerl, R. Hentschel, H. Höness, A. Jacobsen, K. Knapp, E.-D. Knohl, T. Marx, H. Morian, R. Müller, W. Pannhorst, N. Reisert, B. Speit and A. Thomas: *Low thermal expansion glass ceramics*, ed. H. Bach, Chap. 4, p.107 (Springer, Berlin, 1995).

[5] D. Gerlich and M. Wolf: J. Non-Cryst. Solids **27**, 209(1978).

[6] V. G. Badami and M. Linder: Proc. SPIE **4688**, 469(2002).

[7] Y. Takeichi, I. Nishiyama and N. Yamada: Proc. SPIE **6151**, 61511Z(2006).

[8] B. L. Harper, K. E. Hrdina, W. D. Navan, J. Ellison and A. Fanning: Proc. SPIE **5374**, 847(2004).

[9] M. J. Edwards, E. H. Bullock and D. E. Morton: Proc. SPIE **2857**, 58(1996).

[10] K. E. Hrdina, B. Z. Hanson, P. M. Fenn and R. Sabia: Proc. SPIE **4688**, 454(2002).

[11] J. Kushibiki, M. Arakawa, Y. Ohashi, K. Suzuki and T. Maruyama: Jpn. J. Appl. Phys. **43**, L1455(2004).

[12] J. Kushibiki, M. Arakawa, Y. Ohashi, K. Suzuki and T. Maruyama: Jpn. J. Appl. Phys. **44**, 4374(2005).

[13] J. Kushibiki, M. Arakawa, Y. Ohashi and K. Suzuki: IEEE Trans. Ultrason., Ferroelectr., Freq. Contr. **53**, 1627(2006).

[14] M. Arakawa, J. Kushibiki, Y. Ohashi and K. Suzuki: Jpn. J. Appl. Phys. **45**, 4511(2006).

[15] Y. Ohashi, M. Arakawa and J. Kushibiki: Jpn. J. Appl. Phys. **45**, 4505(2006).

[16] Y. Ohashi, J. Kushibiki, M. Arakawa and K. Suzuki: Jpn. J. Appl. Phys. **45**, 6445(2006).

[17] M. Arakawa, J. Kushibiki, Y. Ohashi and K. Suzuki: Jpn. J. Appl. Phys. **45**, 8925(2006).

[18] M. Arakawa, J. Kushibiki and Y. Ohashi: Proc. SPIE **6151**, 615123(2006).

[19] M. Arakawa, Y. Ohashi and J. Kushibiki: Proc. SPIE **6517**, 651725(2007).

[20] J. Kushibiki, Y. Ono, Y. Ohashi and M. Arakawa: IEEE Trans. Ultrason., Ferroelectr., Freq. Contr. **49**, 99(2002).

[21] J. Kushibiki and N. Chubachi: IEEE Trans. Sonics Ultrason. **SU-32**, 189(1985).

[22] J. Kushibiki and M. Arakawa: IEEE Trans. Ultrason., Ferroelectr., Freq. Contr. **45**, 421(1998).

[23] J. Kushibiki, M. Arakawa and R. Okabe: IEEE Trans. Ultrason., Ferroelectr., Freq. Contr. **49**, 827(2002).